

**T** Typ III – do przyspawania

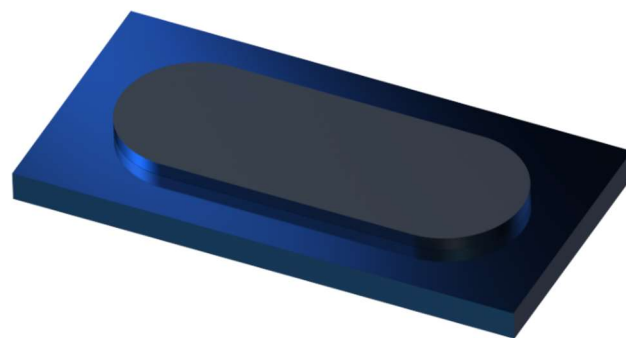

Typ	b x s	l	h	PTFE
III	50x6	100	8	80x30

**T** Typ IV – do przyspawania

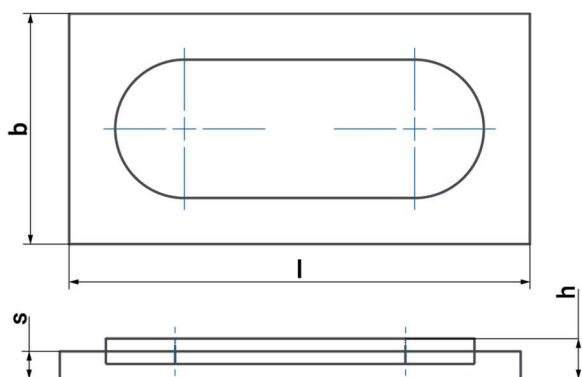
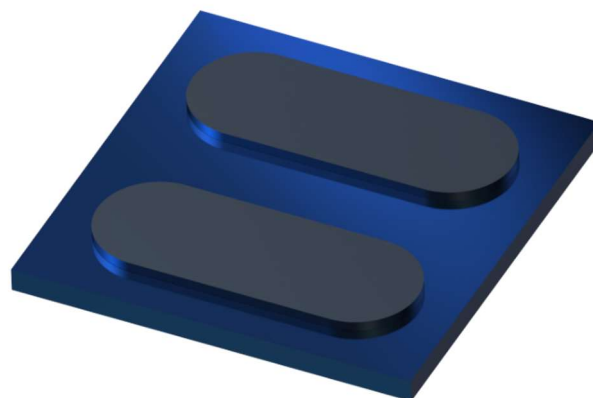
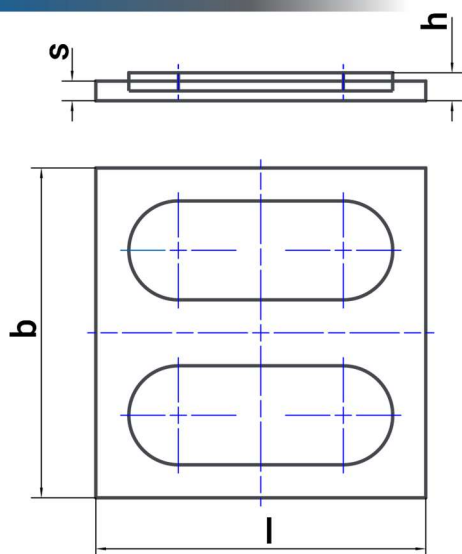

Typ	b x s	l	h	PTFE
IV	100x6	100	8	80x30

**Materiały wytwórcze:**

- ▶ S235
- ▶ wkładka teflonowa z PTFE

**Typy powierzchni pokrycia:**

- ▶ ocynk ogniowy