

Obejma na rury z zaokrąglonymi końcami wg DIN 3567 Typ B

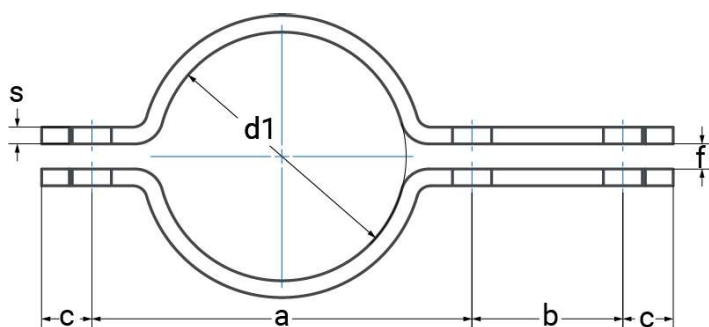

Materiały wytwórcze:

- ▶ S235 ▶ 1.4301 ▶ 1.4571 ▶ 13 CrMo4-5
- ▶ 16Mo3

Typy powierzchni pokrycia:

- ▶ stal surowa ▶ ocynk ogniowy

| Zastosowanie do rur o średnicy DN | | d1 | a | b | c | d2 | f | b x s | Dedykowane śruby (dł.min) | 100 par = kg bez śrub | Nr produktu | | | | | | | | | | | | | | | | | | |
|-----------------------------------|------|------|-----|----|----|------|---|-------|---------------------------|-----------------------|-------------|----|---|------|---------|----|--------|----|---|------|---------|----|--------|----|---|------|---------|----|--------|
| 15 | | 20 | 57 | 46 | 15 | 11,5 | 7 | 30x5 | M 10x35 | 28 | 201010 | | | | | | | | | | | | | | | | | | |
| | ½" | 21,3 | 59 | | | | | | | 29 | 201012 | | | | | | | | | | | | | | | | | | |
| 20 | | 25 | 62 | | | | | | | 54 | 18 | 14 | 9 | 40x6 | M 12x40 | 31 | 201014 | | | | | | | | | | | | |
| | ¾" | 26,9 | 66 | | | | | | | | | | | | | 32 | 201016 | | | | | | | | | | | | |
| 25 | | 30 | 68 | | | | | | | | | | | | | 54 | 18 | 14 | 9 | 40x6 | M 12x40 | 33 | 201018 | | | | | | |
| | 1" | 33,7 | 72 | | | | | | | | | | | | | | | | | | | 35 | 201020 | | | | | | |
| 32 | | 38 | 76 | | | | | | | | | | | | | | | | | | | 54 | 18 | 14 | 9 | 40x6 | M 12x40 | 36 | 201022 |
| | 1 ¼" | 42,4 | 82 | | | | | | | | | | | | | | | | | | | | | | | | | 38 | 201024 |
| 40 | | 44,5 | 84 | 54 | 18 | 14 | 9 | 40x6 | M 12x40 | | | | | | | | | | | | | | | | | | | 39 | 201026 |
| | 1 ½" | 48,3 | 88 | | | | | | | | | | | | | | | | | | | | | | | | | 40 | 201028 |
| 50 | | 57 | 104 | | | | | | | 54 | 18 | 14 | 9 | 40x6 | M 12x40 | | | | | | | | | | | | | 76 | 201030 |
| | 2" | 60,3 | 108 | | | | | | | | | | | | | | | | | | | | | | | | | 77 | 201032 |
| 65 | 2 ½" | 76,1 | 122 | | | | | | | | | | | | | 54 | 18 | 14 | 9 | 40x6 | M 12x40 | | | | | | | 85 | 201034 |
| 80 | 3" | 88,9 | 136 | | | | | | | | | | | | | | | | | | | | | | | | | 95 | 201036 |

| Zastosowanie do rur o średnicy DN | | d1 | a | b | c | d2 | f | b x s | Dedykowane śruby (dł.min) | 100 par = kg bez śrub | Nr produktu | | | | | | |
|-----------------------------------|-----|-------|------|-----|--------|----|----|-------|---------------------------|-----------------------|-------------|----|----|---------|---------|--------|--------|
| 100 | | 108 | 172 | 70 | 24 | 18 | 11 | 50x8 | M 16x55 | 203 | 201040 | | | | | | |
| | 4" | 114,3 | 178 | | | | | | | 206 | 201042 | | | | | | |
| 125 | | 133 | 196 | | | | | | | 220 | 201044 | | | | | | |
| | 5" | 139,7 | 204 | | | | | | | 225 | 201046 | | | | | | |
| 150 | | 159 | 222 | | | | | | | 240 | 201048 | | | | | | |
| | 6" | 168,3 | 232 | | | | | | | 252 | 201050 | | | | | | |
| 175 | 7" | 193,7 | 258 | | | | | | | 280 | 201052 | | | | | | |
| 200 | | 216 | 280 | | | | | | | 300 | 201054 | | | | | | |
| | 8" | 219,1 | 284 | | | | | | | 310 | 201056 | | | | | | |
| 250 | | 267 | 342 | | | | | | | 86 | 30 | 23 | 14 | 60x8 | M 20x60 | 440 | 201060 |
| | 10" | 273 | 348 | 450 | 201062 | | | | | | | | | | | | |
| 300 | 12" | 323,9 | 398 | 510 | 201066 | | | | | | | | | | | | |
| 350 | 14" | 355,6 | 432 | 575 | 201068 | | | | | | | | | | | | |
| | | 368 | 444 | 595 | 201070 | | | | | | | | | | | | |
| 400 | 16" | 406,4 | 498 | 104 | 36 | 27 | 18 | 70x10 | M 24x60 | | | | | | | 960 | 201072 |
| | | 419 | 510 | | | | | | | | | | | | | 980 | 201074 |
| 450 | 18" | 457,2 | 548 | | | | | | | | | | | | | 1035 | 201076 |
| 500 | 20" | 508 | 600 | | | | | | | | | | | | | 1130 | 201078 |
| | | 521 | 614 | | | | | | | | | | | | | 1150 | 201080 |
| 600 | 24" | 609,6 | 702 | | | | | | | 1352 | 201082 | | | | | | |
| 700 | 28" | 711,2 | 830 | | | | | | | 120 | 40 | 30 | 20 | M 27x80 | 2180 | 201084 | |
| 800 | 32" | 812,8 | 930 | | | | | | | | | | | | 2410 | 201086 | |
| 900 | 36" | 914,4 | 1030 | | | | | | | | | | | | 2655 | 201088 | |
| 1000 | 40" | 1016 | 1130 | | | | | | | | | | | | 3740 | 201090 | |