

Uchwyt z pręta okrągłego NW 15-500 wg DIN 3570 Typ A

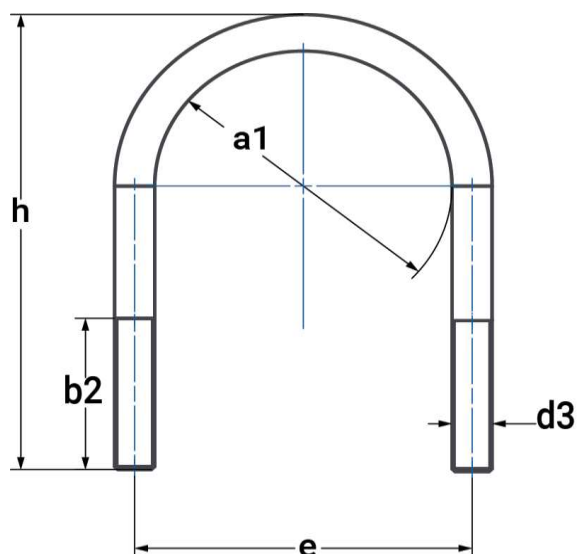

Materiały wytwórcze:

▶ S235 ▶ 1.4301 ▶ 1.4571

Typy powierzchni pokrycia:

▶ stal surowa ▶ ocynk galwaniczny

Dostosowanie do rur o średnicach		a1	Gwint		e	h	100 szt. = kg bez nakrętek	Nr produktu	
NW	d1		b2	d3					
15	22	23	30	M10	33	60	6	421015	
20	25	30	40		40	70	7,4	421020	
	26,9				48	76	8,1	421025	
25	30	38			50	56	86	9,4	421032
	33,7					62	92	10,2	421040
32	38	46	M12			76	109	17	421050
	42,4					94	125	20,3	421065
40	44,5	52	106			138	22,6	421080	
	48,3								
50	57	64							
	60,3								
65	76,1	82							
80	88,9	94							

Dostosowanie do rur o średnicach		a1	Gwint		e	h	100 szt. = kg bez nakrętek	Nr produktu
NW	d1		b2	d3				
100	108	120	60	M16	136	171	54	421100
	114,3							
125	133	148						
	139,7							
150	159	176						
	168,3							
175	191	202						
	193,7							
200	216	70		M20	248	283	140	421200
	219,1							
250	267				282			
	273							
300	318		332					
	323,9							
350	355,6		378	M24	402	435	311	421350
	368							
400	406,4		428					
	419							
500	508		530		554	589	426	421500
	521							